



# Cylinder Carbon Blaster

## A Valuable Tool for Your Octane Unit

The CFR Engines Inc. Cylinder Carbon Blaster is a robustly constructed tool essential for octane combustion chamber cleaning with efficiency and reliability.

Users can easily maximize the operating life of their cylinders and extend the period between mechanical top-end overhauls with regular cleanings using the CFR Cylinder Carbon Blaster.

### Compliance

Recognized industry maintenance technique that helps users maintain operating compliance to strict temperature ranges of ASTM Methods:

D2699 – Research Octane Number

D2700 – Motor Octane Number

D2885 – Online Test Method

### Reliability

Properly timed cleanings with appropriate CFR media will help the cylinder perform to specifications with longer service cycles and increased critical uptime.

### Accuracy

Clean cylinders without excessive deposits and carbon build up, produce accurate octane test results more easily and within a wider, more accommodating operation range.

- Durable design with all-steel components and welded construction
- Nozzle engineered for maximum flow and cleaning efficiency
- Large format valve levers and pressure gauge for ease of use
- Longer operating times with extra capacity media hopper
- Built-in safeties to prevent over-pressure, misconnected hoses, and static discharge
- Environmentally friendly cleaning practice for carbon removal



## Maximize Your Investment

CFR cylinders are designed for long life / operating hours. Users can maximize the productive life of their cylinders by utilizing carbon blasting as a part of their regular overall maintenance practices. Cleaning and regular maintenance reduces damaging deposits and build up, restores temperature tuning ranges, and reduces downtime and cost of permature overhauls.

If the tuned intake air temperature (IAT) for RON or tuned mixture temperature (MIXT) for MON is beyond the lower limit of the specification then the cylinder must be either overhauled or cleaned to remove carbon deposits on the surfaces of the valves, the cylinder, and the piston. The CFR carbon blaster offers a cost effective alternative to a costly top end overhaul. The carbon blasting process in-situ helps to extend the intervals between cylinder overhauls.

## Configurations

Cylinder Carbon Blaster Kit:  
p/n: 3000001

## Specifications

- Air Supply = 16 CFM at 50-70 PSI (345-483 kPa)
- Approximate H x W x D:  
43 cm (17 in) x 46 cm (18 in) x 23 cm (9 in)

## Service Kit Includes:

- Carbon Blaster
- Cleaning Tool / Nozzle
- Cylinder Adapters
- Hoses & Ground Cable
- CFR Approved Blasting Media

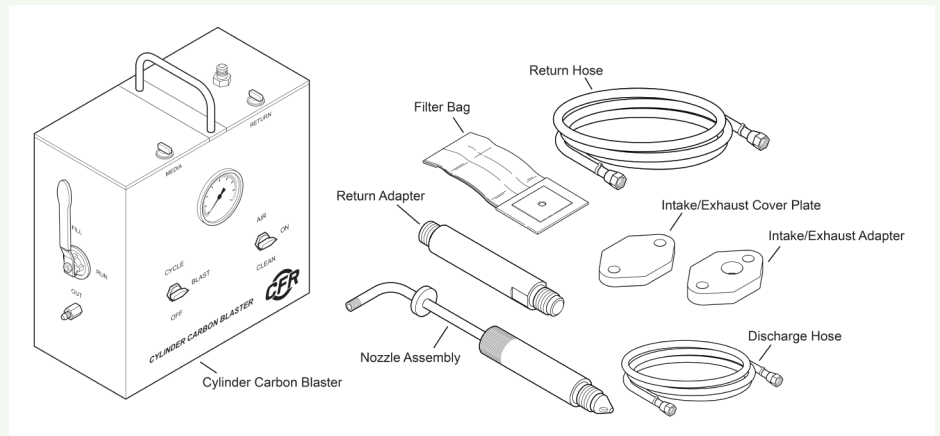
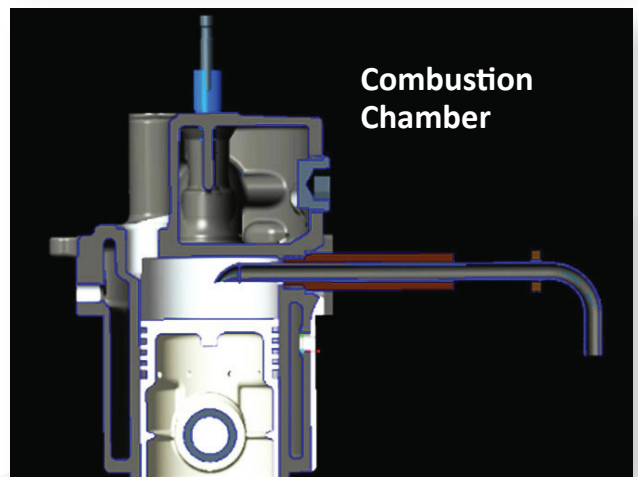
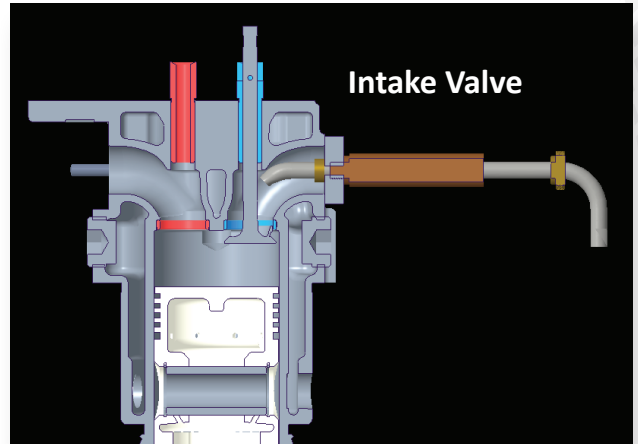

CFR Engines, Inc.  
N8 W22577 Johnson Drive  
Pewaukee, WI 53186

E: [info@cfrengines.com](mailto:info@cfrengines.com)  
T: +1 262 501 5998  
[www.cfrengines.com](http://www.cfrengines.com)

Form C430, Revision B

